

VULCAN

INSTALLATION & OPERATION MANUAL

ROUND ELECTRIC TILTING SKILLET MODEL VECTS16

MODEL

VECTS16

ML-114825



TABLE OF CONTENTS

GENERAL.....	3
INSTALLATION	3
Unpacking	3
Location	3
Installation Codes and Standards	4
Installation	4
Leveling	4
Electrical Connections	4
Floor Plan	5
OPERATION	6
Controls	6
Before First Use	6
Using the Tilting Skillet	6
Cleaning	7
Cooking Guide	8
MAINTENANCE	10
Lubrication	10
Service and Parts Information	10
TROUBLESHOOTING GUIDE	11
NOTES	12

Installation, Operation and Care of ROUND ELECTRIC TILTING SKILLET MODEL VECTS16

PLEASE KEEP THIS MANUAL FOR FUTURE USE

GENERAL

Your Vulcan Round Tilting Skillet is a versatile piece of equipment. It allows you to stew, simmer, pan fry, braise, grill, or saute, and all with a very uniform heat pattern. Capacity of Model VECTS16 is 16 gallons (60.6 L).

Vulcan tilting skillets are produced with quality workmanship and material. Proper installation, usage and maintenance of your tilting skillet will result in many years of satisfactory performance.

It is suggested that you thoroughly read this entire manual and carefully follow all of the instructions provided.

INSTALLATION

Before installing, verify that the electrical service agrees with the specifications on the rating plate located on the right side panel as you face the machine. If the supply and equipment requirements do not agree, do not proceed with the installation. Contact your dealer or Vulcan-Hart Company immediately.

UNPACKING

This tilting skillet was inspected before leaving the factory. The transportation company assumes full responsibility for safe delivery upon acceptance of the shipment. Immediately after unpacking, check for possible shipping damage. If the tilting skillet is found to be damaged, save the packaging material and contact the carrier within 15 days of delivery.

Carefully unpack tilting skillet and place in a work-accessible area as near to its final installed position as possible.

LOCATION

When installed, minimum clearances from combustible and noncombustible construction are 0" at the sides and $\frac{3}{4}$ " (1.9 cm) at the rear.

INSTALLATION CODES AND STANDARDS

The tilting skillet must be installed in accordance with:

In the United States of America:

1. State and local codes.
2. National Electrical Code, ANSI/NFPA-70 (latest edition). Copies may be obtained from The National Fire Protection Association, Batterymarch Park, Quincy, MA 02269.

In Canada:

1. Local codes.
2. Canadian Electrical Code, Part 1, CSA Standard C22.1 (latest edition). Copies may be obtained from The Canadian Standard Association, 178 Rexdale Blvd., Etobicoke, Ontario, Canada M9W 1R3.

INSTALLATION

1. Install skillet on a high working surface.
2. Correct location of skillet for tilting purposes is approximately 30" (76 cm) from the wall to the front of the skillet base. Be sure the skillet tilts easily.
3. With bolts provided, secure skillet to properly leveled working surface.
4. Seal skillet to table top with Silastic or other sealing compound.

LEVELING

Place a carpenter's level on top of the skillet. Level the skillet front to back and side to side.

ELECTRICAL CONNECTIONS

WARNING: ELECTRICAL AND GROUNDING CONNECTIONS MUST COMPLY WITH THE APPLICABLE PORTIONS OF THE NATIONAL ELECTRICAL CODE AND/OR OTHER LOCAL ELECTRICAL CODES.

WARNING: DISCONNECT ELECTRICAL POWER SUPPLY AND PLACE A TAG AT THE DISCONNECT SWITCH TO INDICATE YOU ARE WORKING ON THE CIRCUIT.

The control box for field wire connection is located on the right side as you face the skillet. A knockout hole is provided for a 1" (2.54 cm) conduit connection on the back of the control box.

1. Remove the control box cover plate. Mount suitable 1" (2.54 cm) conduit fitting in knockout opening.
2. Connect field wire to the terminal block as indicated on the wiring diagram. The wiring diagram is located on the inside of the control box cover. Wire must be of the type suitable for 90°C service.

- After making the connections, replace the control box cover plate.
- The tilting skillet must be properly grounded by installing a ground lead to the ground lug located inside the junction box.

ELECTRICAL DATA

Model	Phase	208V		240V		480V	
		kW	Amp	kW	Amp	kW	Amp
VECTS16	1	7.5	36.0	7.5	31.3	N/A	N/A
	3	7.5	20.8	7.5	18.1	7.5	9.0

FLOOR PLAN

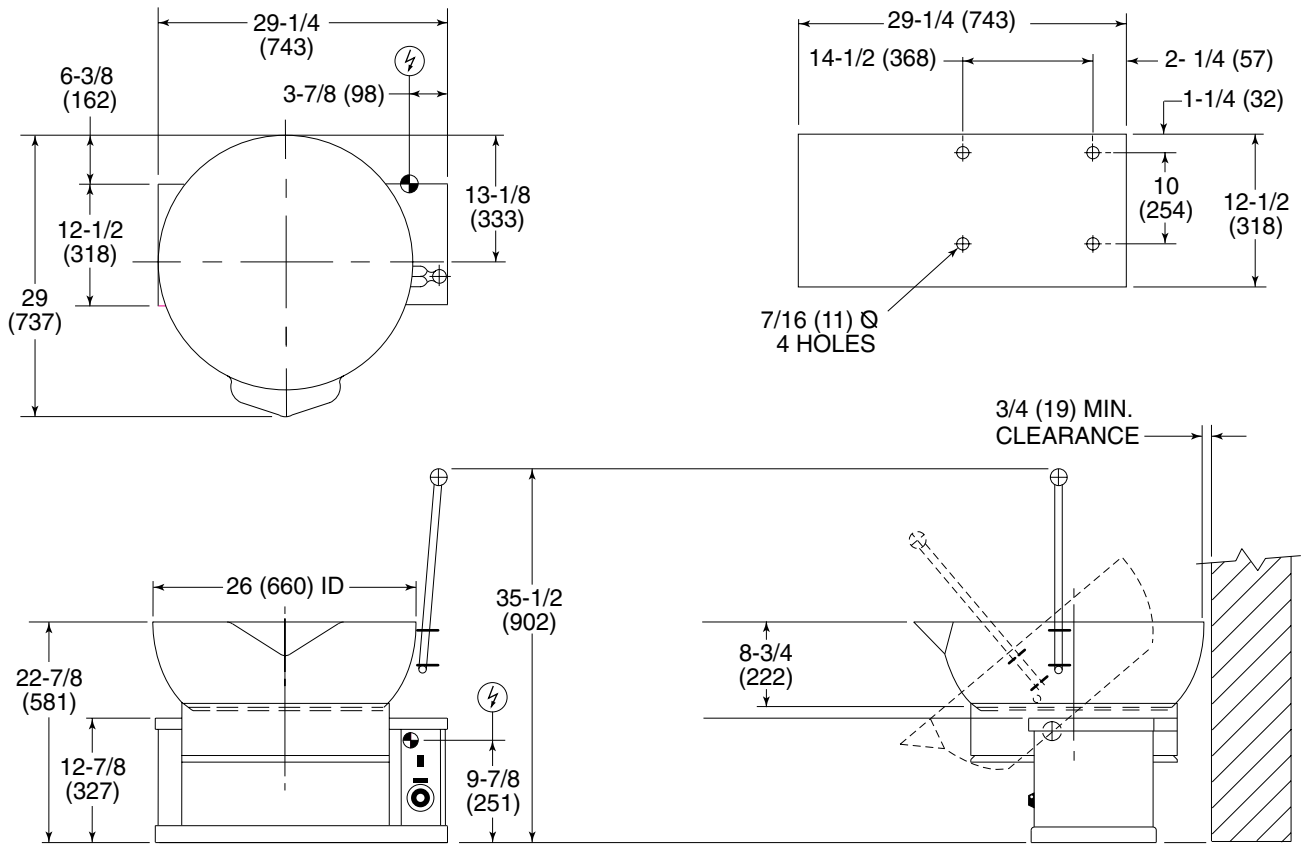

PL-53584

OPERATION

WARNING: THE TILTING SKILLET AND ITS PARTS ARE HOT. USE CARE WHEN OPERATING, CLEANING OR SERVICING THE TILTING SKILLET.

CONTROLS

- Thermostat — Maintains set temperature by controlling power supply. Temperature range is from 100°F to 450°F (38°C to 232°C).
- Power Switch — Turns power to the skillet on and off.
- Indicator Light — When lit, indicates the heating elements are supplying heat to the skillet.
- Tilting Handle — Pull forward to tilt skillet; push backward to return skillet to the down position.

BEFORE FIRST USE

WARNING: BEFORE CLEANING, DISCONNECT ELECTRICAL POWER SUPPLY AND PLACE A TAG AT THE DISCONNECT SWITCH TO INDICATE YOU ARE WORKING ON THE CIRCUIT.

Clean the protective metal oils from all surfaces of the skillet. Use a non-corrosive, grease dissolving commercial cleaner, following manufacturer's directions. Rinse thoroughly and wipe dry with a soft clean cloth. Clean all accessories. Rinse thoroughly and wipe dry.

USING THE TILTING SKILLET

When the skillet is tilted, power supply to the heating elements is interrupted. The skillet can only be operated in the down position.

To prevent discoloration of stainless steel cooking surface, do not turn the heat on unless the skillet is covered with a fluid, a thin layer of cooking oil, or food to be cooked.

1. Grasp the tilting handle and tilt the skillet down as far as it will go and then back to ensure that it moves easily.
2. Turn the Power Switch ON.
3. Set the Thermostat dial to 425°F (218°C).
4. Preheat skillet and allow it to cycle in order to equalize heat across the entire pan surface.
5. Set the Thermostat dial to the desired cooking temperature. See suggested guidelines in the chart on page 7 and the Cooking Guide on pages 8 and 9.
6. At the end of cooking, turn the Thermostat to OFF and turn the Power Switch to OFF.

Function	Approx. Temp.	
	(° F)	(° C)
Simmering	200	93
Sauteing	225-275	107-135
Searing	300-350	149-177
Pan Frying	325-375	163-190
Grilling	350-425	177-218

CLEANING

WARNING: BEFORE CLEANING, DISCONNECT ELECTRICAL POWER SUPPLY AND PLACE A TAG AT THE DISCONNECT SWITCH TO INDICATE YOU ARE WORKING ON THE CIRCUIT.

Do not use corrosive cleaning agents.

After Each Use

The tilting skillet should be cleaned after each use. Clean with warm water and a mild detergent. Rinse thoroughly and wipe dry with a soft clean cloth.

Once A Day

Thoroughly clean the skillet with warm water and a mild detergent. Rinse thoroughly and wipe dry with a soft clean cloth.

Guidelines for Maintaining Stainless Steel Surfaces

There are three basic things that can break down the surface layer of stainless steel and allow corrosion to develop: (1) Abrasion; (2) Deposits and water; and (3) Chlorides.

Avoid abrasion from rubbing with steel pads, wire brushes, or scrapers that can leave iron deposits on stainless steel; instead, use plastic scouring pads or soft cloths. For stubborn stains, use products such as Cameo, Talc, or Zud First Impression. Always rub parallel to the polish lines or with the grain.

Hard water can leave deposits that promote rust on stainless steel. Treated water from softeners or certain filters can eliminate these mineral deposits. Other deposits from food or lubrication must be properly removed by cleaning. Use mild detergent and non-chloride cleaners. Rinse thoroughly. Wipe dry. If using chloride containing cleaners or sanitizers, ***rinse repeatedly*** to avoid stainless steel corrosion. Where appropriate, apply a polish recommended for stainless steel (such as Benefit or Super Sheen) for extra protection and lustre.

COOKING GUIDE

The guidelines given below are only suggestions for quantities, temperature settings, and estimated numbers of orders per load and per hour. When two temperatures are given, the first is to start the product, the second to complete the product.

ITEM	PORTION SIZE	THERMOSTAT SETTING		BATCHES PER HOUR
		°F	°C	
BREAKFAST FOODS				
Bacon	3 Slices	350	177	12
Eggs				
Boiled-Hard	1 Egg	225	107	5
Boiled-Soft	1 Egg	225	107	8
Fried	1 Egg	400	204	4
Poached	1 Egg	225	107	5
Scrambled	1½ Eggs	300 200	149 93	1
French Toast	3 Slices	450	232	7
Regular Oatmeal	½ Cup	250	121	2
Pancakes	2 Each	400	204	10
FISH				
Clams	1 pt. (0.5 kg)	400	204	10
Fish Cakes	2 - 3 oz. (57 - 85 g)	400	204	5
Haddock Filet	4 oz. (113 g)	400	204	4
Halibut Steak	5 oz. (142 g)	450	232	3
Lobster	1 - 1 lb. (454 g)	350	177	4
Swordfish	5 oz. (142 g)	450	232	3
SAUCES, GRAVIES, SOUPS				
Brown Gravy	1 oz. (28 g)	350 200	177 93	2
Cream Sauce	2 oz. (57 g)	250 175	121 79	1
Cream Soup	6 oz. (170 g)	200	93	1
French Onion Soup	6 oz. (170 g)	225	107	1
Meat Sauce	4 oz. (113 g)	350 200	177 93	1
MEAT - POULTRY				
Bacon	3 Slices	350	177	12
Beef				
Chop Suey	6 oz. (170 g)	400 225	204 107	2
Beef Stew	8 oz. (227 g)	300	149	—
Corned Beef Hash	5 oz. (142 g)	400	204	5
Cheeseburger	3 oz. (85 g)	300	149	12
Hamburger	3 oz. (85 g)	300	149	15
Meatballs	1 oz. (28 g)	400 225	204 107	3
Pot Roast	2 oz. (57 g)	350 200	177 93	—
Salisbury Steak	5 oz. (142 g)	400	204	3
Sirloin Steak	6 oz. (170 g)	400	204	5
Swiss Steak	4 oz. (113 g)	300 200	149 93	1

ITEM	PORTION SIZE	THERMOSTAT SETTING		BATCHES PER HOUR
		°F	°C	
MEAT - POULTRY (Continued)				
Chicken - Pan Fried	2 quarters	350	177	3
Chicken - Whole	2 oz. (57 g)	350 200	177 93	—
Hot Dogs - Grilled	2 oz. (57 g)	300	149	8
Hot Dogs - Boiled	2 oz. (57 g)	250	121	12
Ham Steak	3 oz. (85 g)	400	204	8
Pork Chops	5 oz. (142 g)	350	177	4
Sausage Links	3 Links	350	177	7
Turkey				
Off Carcass	2 oz. (57 g)	400 200	204 93	—
On Carcass	2 oz. (57 g)	400 200	204 93	—
MISCELLANEOUS				
Grilled Cheese Sandwiches	1 Sandwich	400	204	8
Macaroni & Cheese	8 oz. (227 g)	200	93	2
Rice	4 oz. (113 g)	350 225	177 107	1
Spaghetti	4 oz. (113 g)	350 225	177 107	2
VEGETABLES				
Canned	3 oz. (85 g)	400	204	6
Fresh				
Beans, Wax, Green	3 oz. (85 g)	400	204	3
Beets	3 oz. (85 g)	400	204	1
Broccoli	3 oz. (85 g)	400	204	3
Cabbage	3 oz. (85 g)	400	204	5
Carrots	3 oz. (85 g)	400	204	2
Cauliflower	3 oz. (85 g)	250	121	5
Corn	1 Ear	400	204	8
Potatoes	3 oz. (85 g)	400	204	2
Spinach	4 oz. (113 g)	250	121	10
Turnip	4 oz. (113 g)	400	204	2
Frozen				
Beans, French Green	3 oz. (85 g)	400	204	6
Lima Beans	3 oz. (85 g)	250	121	4
Broccoli	3 oz. (85 g)	400	204	8
Sliced Carrots	3 oz. (85 g)	250	121	6
Small Whole Carrots	3 oz. (85 g)	250	121	3
Corn	3 oz. (85 g)	250	121	18
Small Whole Onions	3 oz. (85 g)	250	121	7
Peas	3 oz. (85 g)	400	204	10
Spinach	3 oz. (85 g)	400	204	3
DESSERTS, PUDDINGS, SWEET SAUCES				
Butterscotch Sauce	1 oz. (28 g)	200	93	1
Cherry Cobbler	3 oz. (85 g)	200	93	1
Chocolate Sauce	1 oz. (28 g)	200	93	1
Cornstarch Pudding	4 oz. (113 g)	200	93	1
Fruit Gelatin	3 oz. (85 g)	250	121	2

MAINTENANCE

WARNING: THE TILTING SKILLET AND ITS PARTS ARE HOT. USE CARE WHEN OPERATING, CLEANING OR SERVICING THE TILTING SKILLET.

WARNING: DISCONNECT ELECTRICAL POWER SUPPLY AND PLACE A TAG AT THE DISCONNECT SWITCH TO INDICATE YOU ARE WORKING ON THE CIRCUIT.

LUBRICATION

Never grease or oil the pivot bearings as this may cause problems with tilting.

SERVICE AND PARTS INFORMATION

To obtain service and parts information concerning this tilting skillet, contact the Vulcan-Hart Service Agency in your area (refer to listing supplied with the skillet), or Vulcan-Hart Company Service Department at the address or phone number shown on the front cover of this manual.

TROUBLESHOOTING GUIDE

PROBLEM	POSSIBLE CAUSES
Skillet will not operate.	1. Power supply not on. 2. Problem with thermostat or heating elements. Contact your local Vulcan-authorized servicer.
Hot spot on pan bottom.	Problem with heating element. Contact your local Vulcan-authorized servicer.
Skillet difficult to tilt.	Dirt in oilite bearings causing it to bind. Call your local Vulcan-authorized servicer.

— NOTES —